

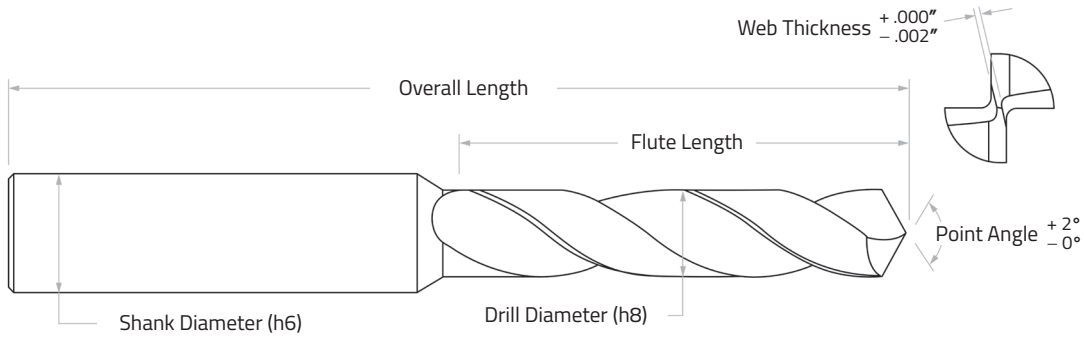

# REQUEST FOR QUOTATION

Please fill in the below information completely and email to [valortech@harveyperformance.com](mailto:valortech@harveyperformance.com). Complete information allows us to respond to your request in a timely fashion and design an optimized tool for your application. If you have any questions about this information, please call 866-840-1505.

## Special Carbide Spot Drill



Drill Diameter: \_\_\_\_\_

Shank Diameter: \_\_\_\_\_

Point Angle: \_\_\_\_\_

Overall Length: \_\_\_\_\_

Length of Flute: \_\_\_\_\_

Web Thickness: \_\_\_\_\_

Workpiece Material: \_\_\_\_\_

Coating: \_\_\_\_\_

Quantity: (6 Piece Min.) \_\_\_\_\_

Comments:

Contact: \_\_\_\_\_

Company: \_\_\_\_\_

Address Line 1: \_\_\_\_\_

Address Line 2: \_\_\_\_\_

City, State, Zip: \_\_\_\_\_ Country: \_\_\_\_\_

Phone / Fax: \_\_\_\_\_ Email: \_\_\_\_\_

Your Preferred Distributor\*: \_\_\_\_\_

\*Valor Holemaking sells through select distribution in the United States & Canada

